

AUPAME

www.aupame.com.br

vendas@aupame.com.br



apogee[®]
INSTRUMENTS

APOGEE FULL-SPECTRUM QUANTUM METER | MQ-500

Features

Accurate, Stable Measurements

Long-term non-stability determined from multiple replicate quantum sensors in accelerated aging tests and field conditions is less than 2 % per year.

Unique Design

Measure photosynthetically active radiation with a research grade, full spectral response sensor. Offers a self-cleaning, cosine-corrected head that is fully-potted for a waterproof design.

Typical PPFD Measurement Applications

- Incoming and reflected PPFD over and under plant canopies in greenhouses, in fields, and in growth chambers
- Aquatic environments including salt water aquariums and freshwater lakes and streams

Calibration Traceability

Apogee SQ-500 sensors are calibrated through side-by-side comparison to the mean of four transfer standard sensors under T5 cool white fluorescent lamps. The transfer standard sensors are calibrated through side-by-side comparison to the mean of at least four quantum sensors under T5 cool white fluorescent lamps traceable to the National Institute of Standards and Technology (NIST).

A research-grade PAR meter with an improved spectral response providing accurate PAR/PPFD measurements under all light sources, including LEDs

Product Specifications

	MQ-500
Calibration Uncertainty	± 5 %
Measurement Range	0 to 4000 $\mu\text{mol m}^{-2} \text{s}^{-1}$
Measurement Repeatability	Less than 0.5 %
Long-term Drift (Non-stability)	Less than 2 % per year
Non-linearity	Less than 1 % (up to 4000 $\mu\text{mol m}^{-2} \text{s}^{-1}$)
Response Time	Less than 1 ms
Field of View	180°
Spectral Range	389 to 692 nm ± 5 nm (wavelengths where response is greater than 50 % of maximum)
Spectral Selectivity	Less than 10 % from 412 to 682 nm ± 5 nm
Directional (Cosine) Response	± 5 % at 75° zenith angle
Azimuth Error	Less than 0.5 %
Tilt Error	Less than 0.5 %
Temperature Response	-0.11 ± 0.03 % per C
Uncertainty in Daily Total	Less than 5 %
Detector	Blue-enhanced silicon photodiode
Housing	Anodized aluminum body with acrylic diffuser
IP Rating	IP68
Operating Environment	0 to 50 C; less than 90 % non-condensing relative humidity up to 30 C; less than 70 % non-condensing relative humidity from 30 to 50 C; separate sensors can be submerged in water up to 30 m
Cable	2 m of shielded, twisted-pair wire; additional cable available; TPR jacket
Warranty	4 years against defects in materials and workmanship

Cosine Response

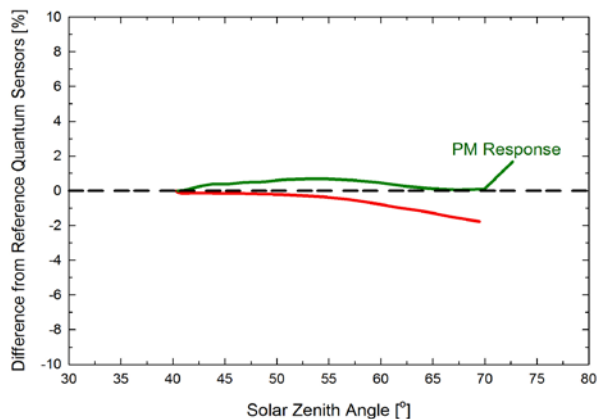

Mean **cosine response** of seven Apogee SQ-500 quantum sensors. Cosine response was calculated as the relative difference of SQ-500 quantum sensors from the mean of replicate reference quantum sensors (LI-COR models LI-190 and LI-190R, Kipp & Zonen model PQS 1). The red data are AM measurements; the green data are PM measurements.

Mean **spectral response** measurements of six replicate Apogee SQ-100 and SQ-500 series quantum sensors. Spectral response measurements were made at 10 nm increments across a wavelength range of 300 to 800 nm in a monochromator with an attached electric light source. Measured spectral data from each quantum sensor were normalized by the measured spectral response of the monochromator/electric light combination, which was measured with a spectroradiometer.

Spectral Response

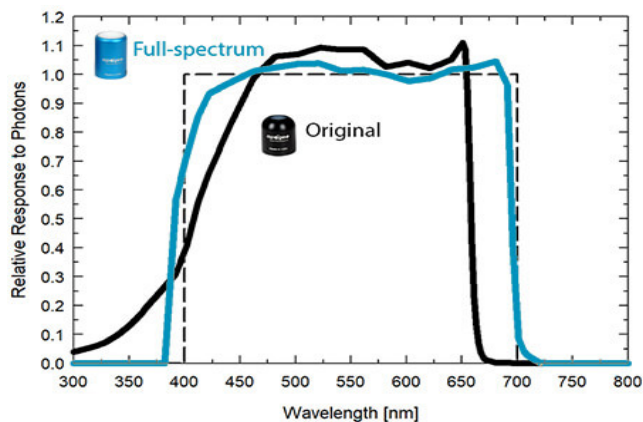

Dimensions

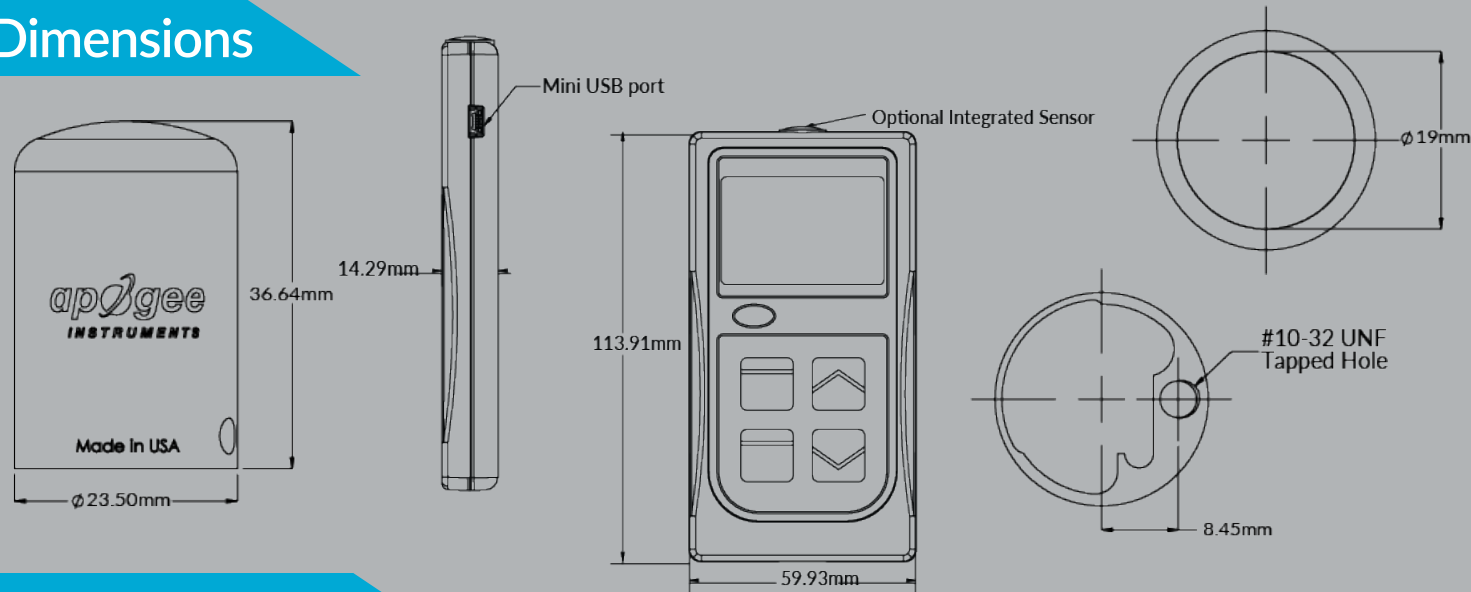

Spectral Errors

	Apogee SQ-500	Apogee SQ-110 SQ-120	LI-COR LI-190	Kipp & Zonen PQS 1
Sun (Clear Sky)	-2.2	0.0	-0.4	-1.0
Sun (Cloudy Sky)	-1.7	1.4	-0.2	-1.3
Sun (Reflected from Deciduous Leaves)	-2.0	4.9	-0.8	1.1
Sun (Transmitted below Wheat Canopy)	-1.1	6.4	-0.1	-0.3
Cool White Fluorescent (T5)	0.0	0.0	0.0	0.0
Metal Halide	0.9	-3.7	0.2	-1.7
Ceramic Metal Halide	-0.3	-6.0	0.4	-0.7
High Pressure Sodium	0.0	0.8	1.3	1.4
Red/Blue LED (16 % 444 nm, 84 % 667 nm peaks)	-3.4	-65.3	3.5	-1.8
Red/White LED (6.5 % 436 nm, 4.5 % 531 nm, 89 % 668 nm peaks)	-3.0	-60.3	2.6	-1.7

Spectral Errors of Commercial Quantum Sensors

Spectral errors are theoretical errors calculated from sensor spectral responses and spectral output of radiation sources. Only spectral errors are listed in the table. Calibration, cosine, and temperature error can also contribute to measurement error.

