



- AGRICULTURE
- AIRPORTS
- BUOY & MARINE
- COASTAL

- HYDROLOGY
- INDUSTRIAL & PLC
- INTRINSICALLY SAFE
- IOT

- METEOROLOGY
- OCEANOGRAPHY
- ROAD MANAGEMENT
- POLAR AND WINTER

- SHIPS
- SKI LIFT & SNOW MAKING
- SMART CITIES
- WEATHER STATIONS

## Wind speed & wind direction



### MeteoWind 2

Anemometer with wind vane. Exceeds **WMO**, **MEASNET** & **Class 1** requirements or accuracy for meteorology & wind resource assessment. Very low 4mA power consumption with inrush protection offer an intrinsically safe solution for hazardous environments. Protected oversize bearings offer superb dirt and weather resistance that has been tested to provide **long-term measurement stability & reliability** in dirty & dusty environments.

### Serviceable bearing & cups with high dirt resistance

- Serviceability of rotor bearing, anemometer cups and wind vane
- Special double-arm reinforced cup design with over-size bearings offer robustness.
- Highest level of 3 stage lightning, EMC, Surge & ESD protection
- Industry standard RS-485 output
- Simple & robust MODBUS RTU and ASCII communication protocol is user selectable
- Long-term tested dirt resistance in highly dusty environments with salt-spray
- *All models feature a weather proof locking bayonet connector.*

### Elliptic cup design offers snow resistance and high accuracy per WMO & MEASNET standards

### Dual arm reinforced cup design for all weather reliability

- WMO & MEASNET compliant wind speed and direction.
- 10Hz sampling rate to accurately capture wind gusts.
- Fast response and minimal over-speeding for accurate wind gust measurement.
- Robust two arm reinforced rotor cup design
- Special flat elliptical cups offer superb snow shedding with very good hail resistance
- Exceptional snow shedding and hail resistance due to an all-metal anodized-aluminum body with special fiber reinforced GRP and UV stabilized black dual-arm cup design

### Heated anemometer with wind vane 25 Watts of heat for all weather reliability

- 25W built in dual heater distributes heat where it is needed most.
- Heater can be controlled manually from a data logger or automatically based on anemometer temperature only or based on anemometer temperature and wind speed.
- Safe operation from 5V up to a 24V DC power source.
- Heater output of can be controlled by input voltage
- 25W at 24V for high reliability all weather deicing
- 6W at 12V with user selectable automatic or manual control for AWOS/AWS weather stations
- Patented flat elliptical cups offer superb winter snow shedding even without heating.

For applications where WMO accuracy and reliability with lightning protection and all-weather resistance is important

## UPGRADE TO INTRINSICALLY SAFE

mechanically strong, 4mA power consumption, inrush protection, triple level lightning, transient, surge, ESD protection.





Measurement standards of anemometer & wind vane				
	Range	Resolution	Accuracy	Sampling rate
Wind speed	0-80 m/s	0.01m/s	< 1% of measured value (0.3 - 50 m/s) or < ±0.2 m/s ±0.05m/s (4-16m/s) with MEASNET CALIBRATION	10Hz @ 3 pulses per revolution
Wind direction	0-360°	1°	2° (no dead-spot)	10Hz
Linearity	R <sup>2</sup> > 0.99995 MEASNET/IEC 61400-12-1:2005			
Tilt angle sensitivity	Cosine response, see graph. (Horizontal wind speed measurement)			
Starting wind speed	<0.3m/s			
Default linearity constants (Calibration equation coefficients)	Defaults: Slope = 0.43 m/s   Offset = 0.33 m/s (m/s = 0.43*freq(Hz) + 0.33) For MEASNET accuracy without calibration: Slope = 0.4341 m/s   Offset = 0.3054 m/s			
Distance constant (Delay distance)	<3m (est.) (per ASTM D 5096-96)			
Electrical specifications of anemometer & wind vane				
Output signal & communication	RS-485 with Modbus RTU & ASCII.			
Supply Voltage	5...24VDC with inrush protection & reverse polarity protection			
Power consumption	4mA (combined wind speed & direction at 10Hz sampling including RS485 communication)			
Lightning & surge protection	per IEC EN 61000-4-5 on both data & power lines, Surge, EFT/Burst, ESD 15kV			
Environmental rating of anemometer & wind vane				
Operating temperature	-40°C to +80°C			
Operating humidity range	0% to 100% RH			
Survival wind speed	>90m/s (324kph, 200mph)			
Connection	Bayonet connector with silicone o-ring			
IP – Protection rating	IP55W (DIN 40050)			
General anemometer & wind vane specifications				
Heater (optional)	25W (1.1A) @ 24VDC (6W @ 12VDC), User selectable manual or automatic heater control			
Weight (mass)	Anemometer = aprox. 300g (without stainless steel mount)			
Dimensions	Anemometer rotor diameter = Ø164mm, Wind vane radius = 136mm, Total height = 320mm			
Patented	OHIM 002153882-0001, 002153882-0002, 002153882-0003			
Mounting	two M4 screws with supplied holder as pictured below			

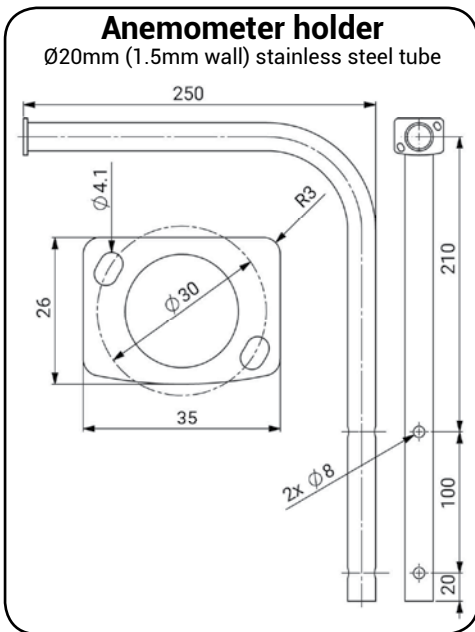

### Compact design

Combining of the anemometer and wind vane electronics allows this compact design to shine. Improved levels of reliability are made possible due to the reduction of electrical components. Compact size increases anemometer accuracy and reduces snow buildup for improved winter operations and more effective heater deicing.

Other customer related benefits from this combined wind sensor include:

- Reduction in the number of connectors & wiring for better weather & lightning resistance
- Reduction in mounting hardware and installation time
- Simpler & faster maintenance
- Simpler data logger configuration

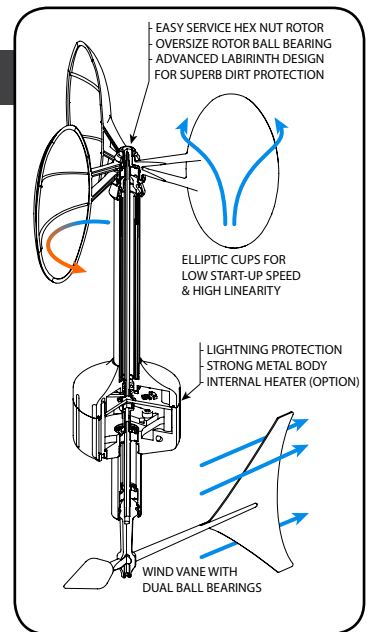

Reach your Gold Standard of measurement with BARANI sensors. ISO:9001 quality.

